

OCP

C-Frame Single Crank Power Presses

C型單曲軸沖床



25. 35. 45. 60. 80. 110. 160. 200. 260 ton

OCP

C-Frame Single Crank

C型單曲軸沖床

- Improve Stamping Quality
- Reduce Noise & Vibration
- Increase Operability Improve Comfort & Safety in Pressworking
- 高精密加工的實現
- 降低噪音與沖床的震動
- 人性化的操作

- Reduce Variation of Die Height
- Prolong Toolings' Life
- Minimize Frame Deflection
- Increase Permissible Off-center Load
- 模高變化小，動態中心偏差小
- 模具壽命大幅提升
- 沖壓之變形量小
- 左右偏心負荷強

- High Performance Wet Type Clutch/Brake with Auto-forced Air Cooling
- Extra Long 6-Point Centered Gibs
- Super Rigid Steel Frame
- Reduced Total Clearance
- Multi-Function Press Control
- 強制空冷式濕式離合剎車器
- 固鎖式六面導路
- 高剛性機身
- 低總合間隙
- 多功能的沖床控制器



Power Presses

Stroke-Capacity Diagram (L)
行程-能力曲線圖 (L)

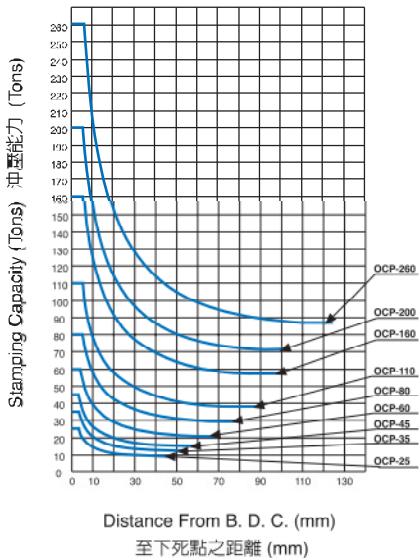

Stroke-Capacity Diagram (S)
行程-能力曲線圖 (S)

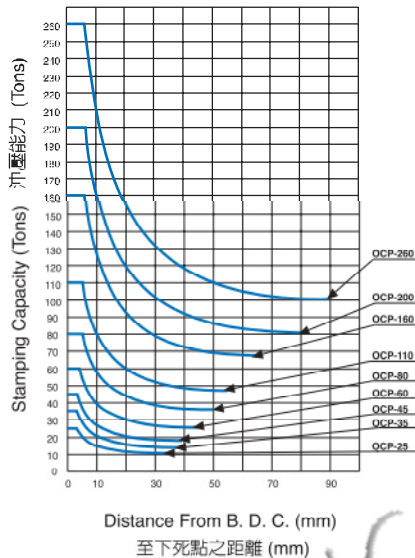

Stroke-Capacity Diagram (H)
行程-能力曲線圖 (H)

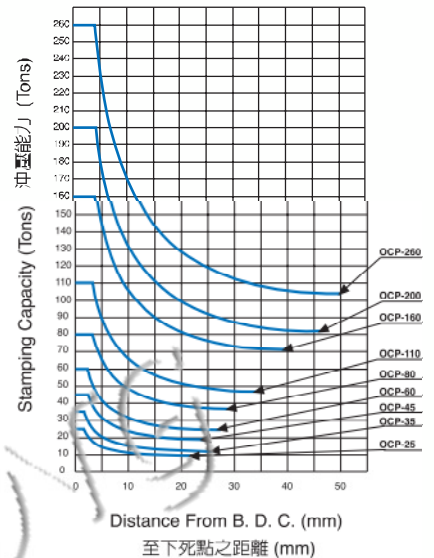

SPECIFICATIONS 規格 (W)

TYPE 型式	MODEL 機種	OCP-25				OCP-35				OCP-45				OCP-60				OCP-80				OCP-110				OCP-160				OCP-200				OCP-260																																											
		S	H	L	XL	S	H	L	XL	S	H	L	XL	S	H	L	XL	S	H	L	XL	S	H	L	XL	S	H	L	XL	S	H	L	XL																																												
Capacity 能力	Tons	25				35				45				60				80				110				160				200				260																																											
Rated tonnage point (above B.D.C.) 能力發生點	mm	3.2	1.6	3.2		3.2	1.6	3.2	3.2	2.3	3.2	4	2.3	4	5	3.2	5	5	3.2	5	5	6	4	6	6	4	6	6.5	4	6.5																																															
Stroke length 行程長	mm	70	40	100		80	45	110	80	50	120	90	55	140	100	60	160	110	70	180	130	80	200	250	150	95	200	250	180	100	250	300																																													
Strokes per minute 行程數	Fixed 定速 S.P.M.	95				90				80				70				60				50				45				35				30																																											
	Variable 變速 S.P.M.	75-140	95-180	55-100		70-135	90-180	50-95		65-130	85-175	50-95	60-120	80-165	40-85	55-110	75-150	40-75		50-100	65-135	30-65	40-85	55-115	25-50	20-45	35-70	45-95	20-45	20-40	30-60	40-75	20-40	20-35																																											
Die height (S.D.A.U.) 最大模高	mm	245	230			250	235			250	270			270	300			300	330			320	350			350	450			410	450			460	500	540																																									
Maximum upper die weight 最大上模重量	kg	300				300				300				400				450				700				800				800																																															
Slide adjustment 滑塊調整量	mm	50				55				60				70				80				90				100				120																																															
Bolster area (L.R. x F.B.) 台盤面積	mm	720x320				780x340				850x360				900x400				1000x460				1100x520				1250x600				1400x680				1500x700				1530x750																																							
Bolster thickness 台盤厚度	mm	70	85	70		70	85	70		90	105	90		90	107.5	90		100	120	100		120	140	120		150	175	150		160	187.5	160		180	220	180																																									
Slide area (L.R. x F.B.) 滑塊面積	mm	350x300				380x320				430x350				500x400				560x460				650x520				700x580				850x650				920x700																																											
Main motor 主電機	Fixed 定速 kWxp	-	2.2x4			-	2.2x4			-	3.7x4			-	3.7x4			-	5.5x4			-	7.5x4			-	11x4			-	15x4			-	18.5x4																																										
	Variable 變速 kWxp	VS 3.7x4				VS 3.7x4				VS 5.5x4				VS 5.5x4				VS 7.5x4				VS 11x4				VS 11x4				VS 15x4				VS 18.5x4																																											
Slide adjusting motor 滑塊調整馬達	kWxp	Manual				Manual				0.4x4				0.4x4				0.4x4				0.4x4				0.75x4				0.75x4				1.5x4																																											
Die cushion 模墊																																																																													
Capacity 能力	ton	-				2.6				2.6				3.6				6.3				8				10				14				14																																											
Pad area (L.R. x F.B.) 模墊頂板面積	mm	-				300x230				335x230				350x235				410x260				500x300				540x350				640x470				700x470																																											
Stroke 行程長	mm	-				50				60				70				70				80				80				100				100																																											
Machine dimension 機械尺寸																																																																													
Width L.R. 機械寬度	mm	900				930				1055				1020				1113				1245				1420				1500				1520				1580				1767				2067																															
Depth F.B. 機械深度	mm	1025				1200				1685				1725				1755				1815				1820				1890				2045				2175				2180				2308				2405				2465				2240				2400				2550											
Height H. 機械高度	mm	1870				2100				2305				2365				2495				2575				2764				2854				2990				3030				3270				3390				3490				3665				3755				3805				4150				4290				4380			

*S & H Type Cannot be Equipped with DIE Cushion.

*模墊僅限於L、XL型式才有裝置

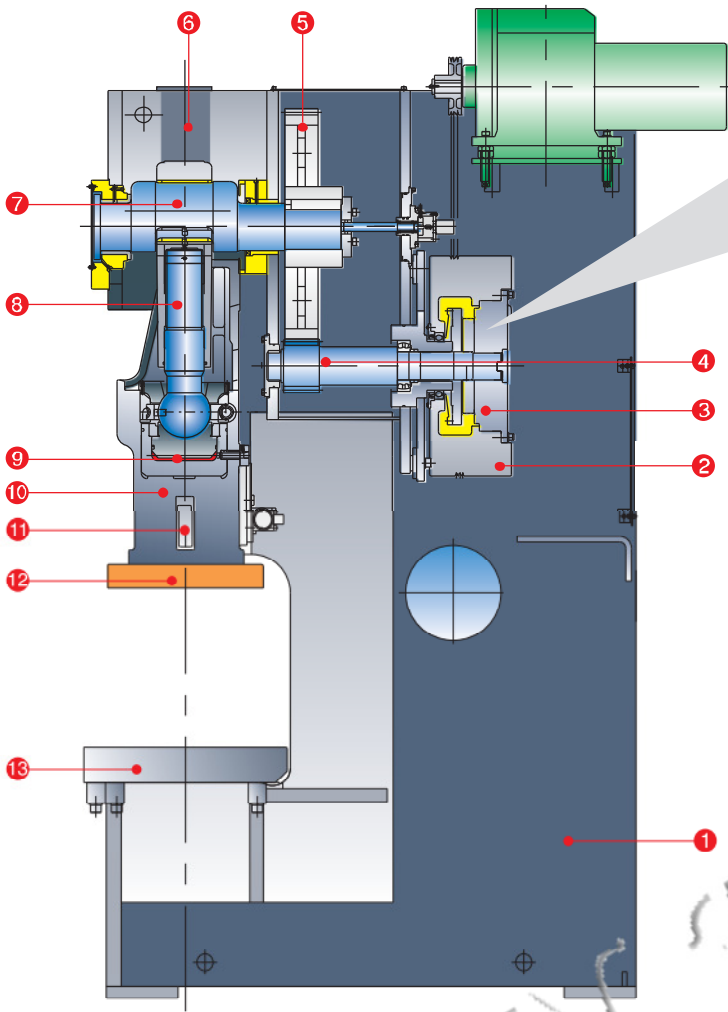

High Driving Torque Wet Clutch & Brake

高傳動扭矩濕式離合剎車器

高性能
高效率
低慣性
高扭矩

低噪音
無粉塵
長使用壽命
低維修成本

The Chin Fong clutch delivers rated torque at relatively low air pressure, resulting in reduced lining wear and air consumption.

Life of clutch and brake linings is extended by effective heat dissipation resulting from linings running in an enclosed oil bath.

Low moment of inertia significantly reduces wear on linings. Modern suited friction linings combine high performance with low vibration and noise.

- | | |
|---------------------------------|---------------|
| 1. Press Frame | 1. 台身 |
| 2. Flywheel | 2. 飛輪 |
| 3. Wet Clutch & Brake | 3. 濕式離合剎車器 |
| 4. Pinion Drive Shaft | 4. 傳動軸 |
| 5. Main Gear | 5. 大齒輪 |
| 6. Counter Balancer | 6. 平衡器 |
| 7. Crankshaft | 7. 曲軸 |
| 8. Adjusting Screw | 8. 鋸牙 |
| 9. Hydraulic Overload Protector | 9. 過負荷油室 |
| 10. Slide | 10. 滑塊 |
| 11. Slide Knockout | 11. 頂料裝置 |
| 12. Slide Plate (Detachable) | 12. 滑塊板 (可卸式) |
| 13. Bolster | 13. 台盤 |

Super Rigid Steel Frame

超高剛性台身

結構剛性最佳化
沖壓製品精度大幅提升
模具壽命有效延長

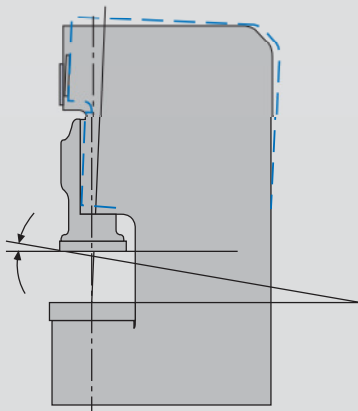

The Chin Fong OCP Series is designed to resist deflection, and provide accurate pressings and longer die life, even at full tonnage loads. The heavy, one-piece welded steel frame is fully stress relieved and designed to provide a stable base for the OCP Series presses.

Highly Responsive Hydraulic Overload Protector (H.O.L.P.)

高感度過負荷保護裝置

快速反應過載
瞬間油壓洩載

1. Spherical Seat
2. Hydraulic Overload Protector Cylinder
3. Overload Protector
4. Oil Tank

1. 球座
2. 油壓緩衝缸
3. 過負荷保護裝置
4. 油箱

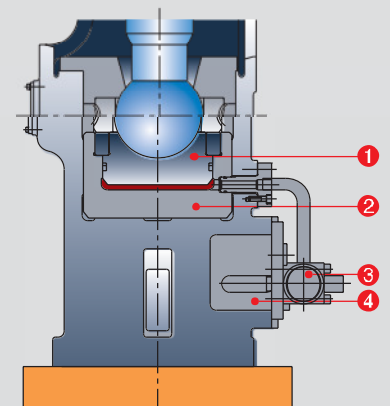

Chin Fong's fast response H.O.L.P. will relieve the pressure of a tonnage overload in milliseconds, causing the press to stop simultaneously. Press and toolings can therefore be protected effectively. Hydraulic pressure of the system can be rebuilt by pushing reset button. Press, then, resume normal operation when inching the slide up to TDC position.

Box Type Six-Point Gibs

高精度六面導路

超長導路精度高
側向力台身直接吸收，導路精度穩定性極佳。

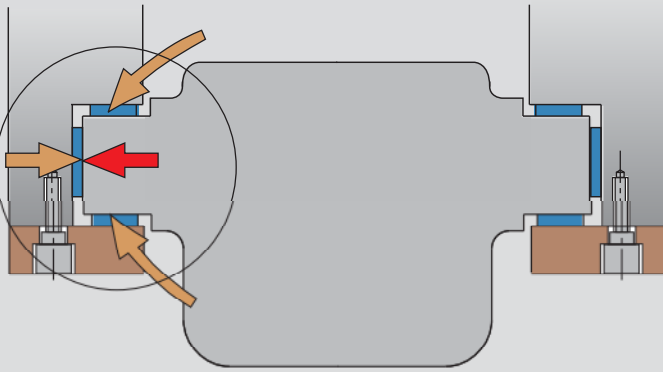

One-piece, full-length, box type gibs assure actuated slide guiding. Force is delivered vertically, minimizing lateral thrust and, consequently, reducing off-center loading and friction in the gibs.

Minimize Frame Deflection

最小機身變形

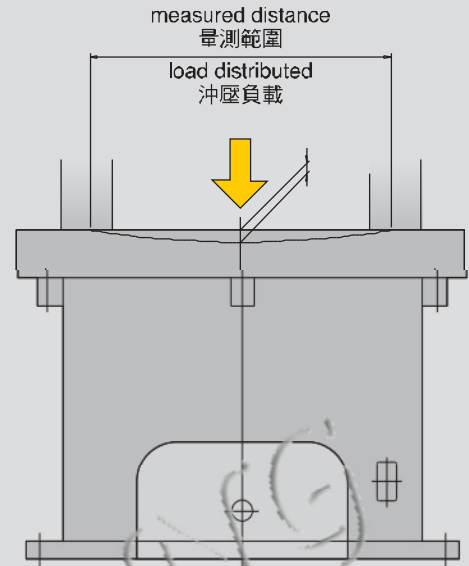

(For reference only. Select the items below properly as needed. 以下型式、規格及數量之選配，僅供參考)

Quick Die Change System 便利的快速換模系統 (Q. D. C. S.)

Die Clamp TX-type

TX型夾模器

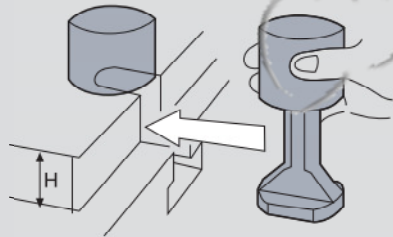

With "U" Cut in die set
模板"U"形溝

Die Clamp TY-type

TY型夾模器

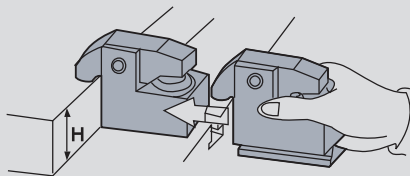

Die plate thickness, H, to be specified
模板厚: H (請確認厚度)

Option 選用配置		Qty 數量	Model 機型	OCP-25 OCP-35 OCP-45 OCP-60 OCP-80 OCP-110 OCP-160 OCP-200 OCP-250															
				S		H		L		S		H		L		XL			
Die Clamp 夾模器	Upper 上模	TX-2 or TY-2 TX-2 或 TY-2	Clamping Force 2 tons/pc 夾持力2噸/個	4	4	4	4												
		TX-4 or TY-4 TX-4 或 TY-4	Clamping Force 4 tons/pc 夾持力4噸/個					4	4										
	TX-6 or TY-6 TX-6 或 TY-6	Clamping Force 6 tons/pc 夾持力6噸/個							4	4			4	4					
Die Clamp 夾模器	Lower 下模	TX-2 or TY-2 TX-2 或 TY-2	Clamping Force 2 tons/pc 夾持力2噸/個	4	4	4	4												
		TX-4 or TY-4 TX-4 或 TY-4	Clamping Force 4 tons/pc 夾持力4噸/個					4	4	4									
		TX-6 or TY-6 TX-6 或 TY-6	Clamping Force 6 tons/pc 夾持力6噸/個													4	4		
Die Lifter 舉模器	DL28-400	Pay Load 1.1 tons/pc 載模力1.1噸/個				2	2		2										
	DL28-500	Pay Load 1.2 tons/pc 載模力1.2噸/個							2			2							
	DL28-600	Pay Load 1.4 tons/pc 載模力1.4噸/個									2	2	2		2				
	DL28-700	Pay Load 1.5 tons/pc 載模力1.5噸/個													2			2	
	DL28-800	Pay Load 1.6 tons/pc 載模力1.6噸/個															2	2	
Die Arm 移模臂	RC-700-600	Pay Load 600 kg/pc 承載力600kg/個		2	2	2	2	2	2	2									
	RC-800-800	Pay Load 800 kg/pc 承載力800kg/個												2					
	RC-900-900	Pay Load 900 kg/pc 承載力900kg/個														2	2		
Hydraulic Power Unit FP6308U 油壓動力單元FP6308U				1															

BOLSTER 台盤

Fig. 1 圖一

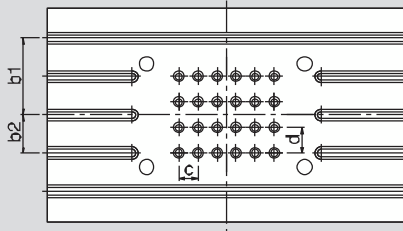

Fig. 2 圖二

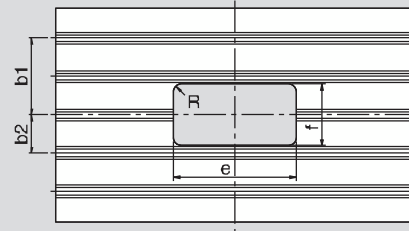

Fig. 3 圖三

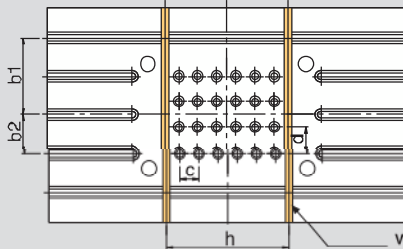
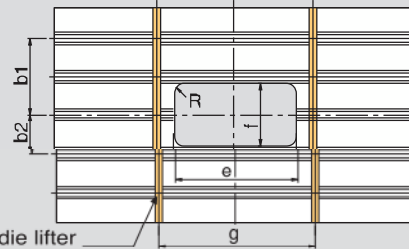

Fig. 4 圖四



with "U" slot for die lifter
含舉模器用"U"型溝

unit: mm

MODEL	機種	OCP-25	OCP-35	OCP-45	OCP-60	OCP-80	OCP-110	OCP-160	OCP-200	OCP-250
Type of T-Slot	T型槽型式	C	C	C	A	A	B	B	B	B
No. of T-Slot	T型槽條數	3	3	3	3	3	5	5	5	5
No. of Pin Hole x Dia.	模墊銷孔數目x孔徑	-	-	15 x $\phi 20^{+0.5}_{-0.1}$	15 x $\phi 20^{+0.5}_{-0.1}$	24 x $\phi 20^{+0.5}_{-0.1}$	24 x $\phi 26^{+0.5}_{-0.1}$	24 x $\phi 26^{+0.5}_{-0.1}$	35 x $\phi 28^{+0.5}_{-0.1}$	35 x $\phi 28^{+0.5}_{-0.1}$
c x d		-	-	75 x 85	75 x 100	75 x 75	90 x 90	100 x 100	100 x 100	100 x 100
b1		120	120	150	150	150	250	300	300	300
b2		-	-	-	-	-	150	150	150	150
e x f		260 x 130	280 x 140	300 x 150	320 x 160	360 x 180	400 x 200	440 x 220	480 x 240	520 x 260
R		20	20	20	20	30	30	30	30	30
g		400	400	420	420	480	480	520	560	580
h		-	-	360	370	440	530	580	680	700

SLIDE PLATE 滑塊板加工圖

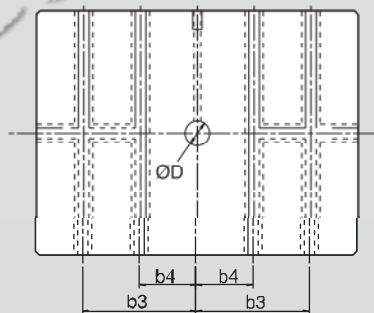

unit: mm

MODEL	機種	OCP-25	OCP-35	OCP-45	OCP-60	OCP-80	OCP-110	OCP-160	OCP-200	OCP-260
Slide Plate Area (LR x FB)	滑塊板面積 (左右x前後)	350x300	380x320	430x350	500x400	560x460	650x520	700x580	850x650	920x700
Type of T-Slot	T型槽型式	C	C	C	A	A	B	B	B	B
No. of T-Slot	T型槽條數	2	2	2	2	2	2	4	4	4
Shank Hole Dia. D	模柄孔徑	Ø 38	Ø 38	Ø 38	Ø 50	Ø 50	Ø 50	Ø 65	Ø 65	Ø 65
b3		100	100	125	125	150	150	300	300	300
b4		-	-	-	-	-	-	150	150	150

T-Slot Detail T型槽詳細

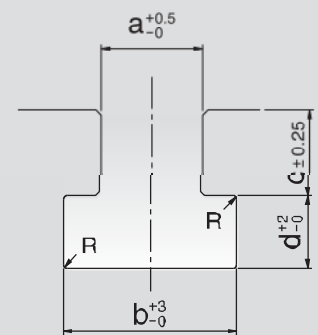

unit: mm

Dim. 尺寸	Type 型式	A	B	C
a		22	28	18
b		37	48	30
c		24	28	18
d		16	20	12
R		1	1	1

OUTLINE DIMENSIONS

外型尺寸

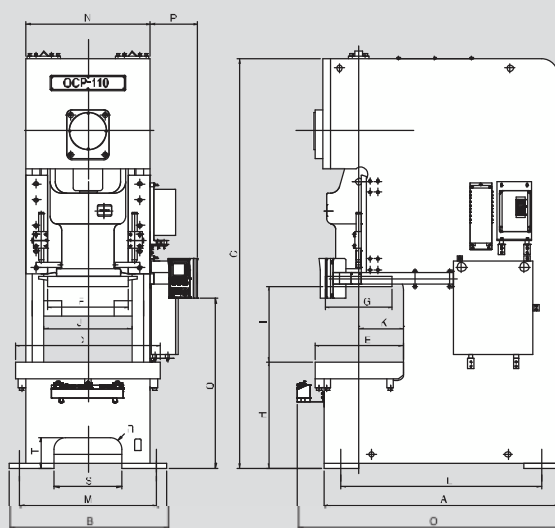

unit: mm

MODEL	OCP-25			OCP-35			OCP-45			OCP-60			OCP-80			OCP-110			OCP-160			OCP-200			OCP-260					
機種	S	H	L	S	H	L	S	H	L	S	H	L	S	H	L	S	H	L	S	H	L	XL	S	H	L	XL	S	H	L	XL
A	1050			1190			1313 1358			1320 1382			1493 1565			1700.5 1770.5			1935 2000			2162.5 2225			2330 2430					
B	810			840			870			980			1120			1240			1360			1520 1590			1700 1800					
C	2070			2210			2305 2345			2500 2555			2805 2865			2965 3030			3385 3520			3755 3820			4205 4290 4380					
D	720			780			850			900			1000			1150			1250 1350			1400 1500			1500 1750					
E	320			340			360 440			400 520			460 600			520 680			600 760			680 820			700 900					
F	350			380			430			500			560			650			700			850			920					
G	300			320			350			400			460			520			580			650			700					
H	800	815	800	800	815	800	800	815	800	800	817.5	800	833	853	833	840	860	840	915	940	915	1010	1037.5	1010	1100	1140	1100			
I	315	285	330	330	295	345	330	300	390	360	325	440	400	360	490	430	390	530	480	430	550	700	560	505	650	700	640	560	750	840
J	478			502			510			534			598			660			750			850			910 1050					
K	165			175			190 230			210 270			240 310			270 350			335 390			350 420			390 460					
L	830			960			1073 1118			1104 1166			1233 1305			1460.5 1530.5			1635 1700			1812.5 1875			1790 1890					
M	680			710			740			830			900			1050			1180			1320 1430			1470 1570					
N	600			630			660			730			830			950			1070			1190 1250			1350 1450					
O	1280			1420			1543 1588			1550 1612			1723 1795			1930.5 2000.5			2165 2230			2392.5 2455			2560 2660					
P	270			270			270			270			408			408			408			408			408					
Q	1180			1345			1335			1360 1370			1385 1440			1415 1480			1590 1460			1450			1380 1420					
R	80			80			40			50			50			100			100			100			100					
S	360			360			370			400			480			540			580			720			710					
T	340			343			300			300			283			280			265			285			330					

Standard Functions / Accessories

- Fixed Type Operation Stand
- E-Series Control System
 - Electronic Crank Angle Display
 - Electronic SPM Display
 - LCD type Press status monitor
- Operation Mode Selection
 - Off / Inching / Safety One Stroke / Continuous
- Hydraulic Overload Protector (H.O.L.P)
- Overrun Detector
- Door interlocking power isolation switch
- Dual-coiled Solenoid Valve
- Motorized Slide Adjustment (45-260 Ton)
- Die Height Indicator (Unit:0.1mm)
- Motorized Grease Lubrication Device
- Total Counter, 6 digits
- Preset Counter, 6 digits
- Maintenance Counter, 4 digits (Unit:10K)
- Life Counter 10 digits
- Electronic Rotary Cam Switch, 6 spare channel
- Air Ejector, 3/8"
- Air Source Receptacle, 3/8"
- Misfeed Detection Consent

標準附屬品

- 固定式雙手按鈕操作台
- E電控
 - 電子式曲軸角度指示器
 - 電子式運轉速度指示器
 - 運轉狀態LCD監視器
- 運轉模式選擇
 - 切 / 寸動 / 安全一行程 / 連續
- 油壓過負荷保護裝置
 - 一度薄保護裝置
 - 蓄氣箱斷電開關
- 雙聯電磁閥
- 電動滑塊調整裝置 (45-260 Ton)
- 數字式模高指示器 (單位: 0.1mm)
- 電動黃油潤滑裝置
- 累計計數器6位數
- 預調計數器6位數
- 保養計數器4位數 (單位:萬)
- 壽命計數器10位數
- 電子式旋轉凸輪開關 預備6連
- 噴風裝置3/8"
- 空氣源接頭3/8"
- 誤送檢知插座

Optional Functions / Accessories

- Die Cushion
- VS Motor (Not Applicable to E-Series Control System)
- Control System MPC Series
- PLC Controller
- Photoelectric Safety Device
- Upper Slide Knockout Device
- Inverter & Main Motor Reversing Circuit Device
- Portable 2-hand Pushbutton T-stand
- Safety Block with plug
- Dual-coiled Solenoid Valve with Detector
- Load Monitor Device
- Flywheel Brake Device
- Power Receptacle (Single phase, 110V / 220V power source wiring by user)
- Power Take-off Shaft
 - Crankshaft Front-end Extension
 - Left-hand-side Frame Extension (Feed Direction: Left to Right)
- Quick Die Change System
- Foundation Anchor Bolts & Plates
- Anti-Vibration Press Mounts
- Die Area Light

特殊附屬品

- 模墊裝置
 - VS馬達 (非E電控使用)
- 沖床控制器MPC系列
- PLC可程式控制器
- 光電安全裝置
- 滑塊上部頂料裝置
- 變頻器與主馬達正逆轉裝置
- T型操作台
- 安全檔塊及安全插銷
- 附檢知雙聯電磁閥
- 荷重計
- 飛輪剎車裝置
- 電源插座110V或220V單相 (電源客戶自備)
- 送料軸端
 - 曲軸前端延伸式
 - 台身左側接出式 (送料方向: 左→右)
- 快速換模裝置 (O.D.C.S.)
- 基礎螺絲及基礎板
- 防震裝置
- 模貝照映燈
- 電子式角度控制器



沖壓機械專業製造廠

CHIN FONG

INNOVATION, SERVICE, COMMITMENT

金豐機器工業股份有限公司

CHIN FONG MACHINE INDUSTRIAL CO., LTD.

HEAD OFFICE & FACTORY:

總公司: 台灣省彰化市彰水路186號
186 Chang Shui Road, Chang Hua, Taiwan
http://www.chinfong.com.tw
E-mail: sales@chinfong.com.tw
TEL: +886-4-752-4131
FAX: +886-4-761-1920, 761-2814

北區營業所 TAIPEI OFFICE

TEL: +886-3-435-5058
FAX: +886-3-463-9648

南區營業所 KAOHSIUNG OFFICE

TEL: +886-7-238-5689~90
FAX: +886-7-238-5691

OVERSEAS BRANCHES

金豐 (中國) 機械工業有限公司

CHIN FONG (CHINA) MACHINE INDUSTRIAL CO., LTD.

寧波市鎮海經濟開發區金豐路3號
3 Chin Fong Road, Zhenhai Economic Development Zone, Ningbo, China
TEL: +86-574-8630-1222
FAX: +86-574-8630-3709
http://www.chinfong.com.cn
E-mail: ge0107@chinfong.cn



U.S.A.: STAMTEC INC.

4160 Hillsboro Highway Manchester, TN 37355, U.S.A.
TEL: +1-931-393-5050
FAX: +1-931-393-5060
http://www.stamtec.com
E-mail: Salse@stamtec.com

THAILAND: CHIN FONG (THAILAND) CO., LTD.

E-mail: chinfong@chinfong.co.th
TEL: +66-2-919-6820~2 FAX: +66-2-919-6823

INDONESIA: PT. CHIN FONG INDONESIA

E-mail: info@chinfong.co.id
TEL: +62-21-450-7422 FAX: +62-21-456-44197

MALAYSIA: CHIN FONG MACHINE (M) SDN BHD

E-mail: chinfongmachine@gmail.com
TEL: +60-3-38853155



The contents disclosed in this catalogue, including pictures, data, wordings & drawings, are exclusive property of Chin Fong Machine Industrial Co., Ltd. Unauthorized duplication or use part or whole of this catalogue is prohibited. Chin Fong reserves rights to modify the specifications & features, due to product improvements, without further notification. optional accessories showing on this picture are for reference only.

以上資料及圖片均屬本公司之產權，不得抄襲仿冒。且本公司得因產品之改良逕行設計變更，不另行通知。照片內之貨物屬選用配備，僅供參考。